

NOTES

1. THE DIMENSIONS GIVEN FOR THE KEYS ARE FOR REFERENCE ONLY AND SHOULD BE MODIFIED TO SUIT THE PLAYER.
2. THE C# AND THE D# KEYS CAN BE IDENTICAL
3. THE KEY MODELS DO NOT HAVE THE SMOOTH CURVES AND RADIUSED EDGES OF THE REAL KEYS AND THIS IS LEFT TO THE MAKER TO ADD.

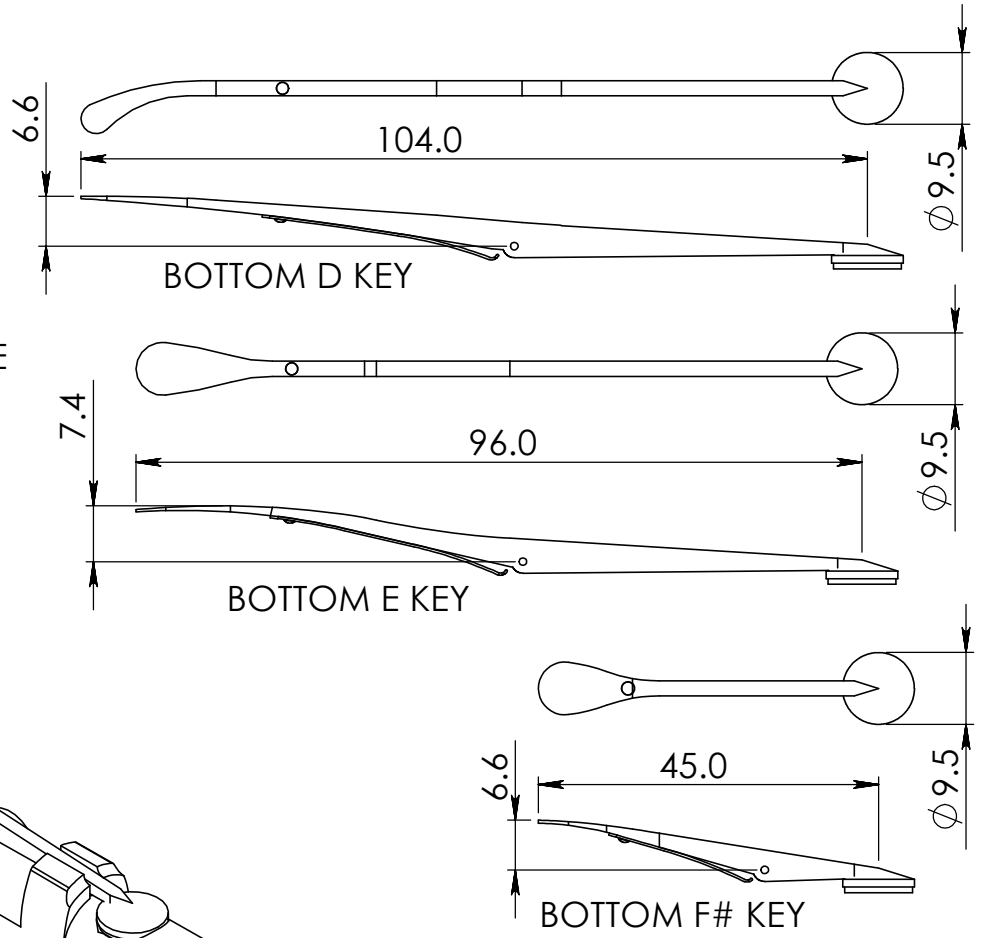
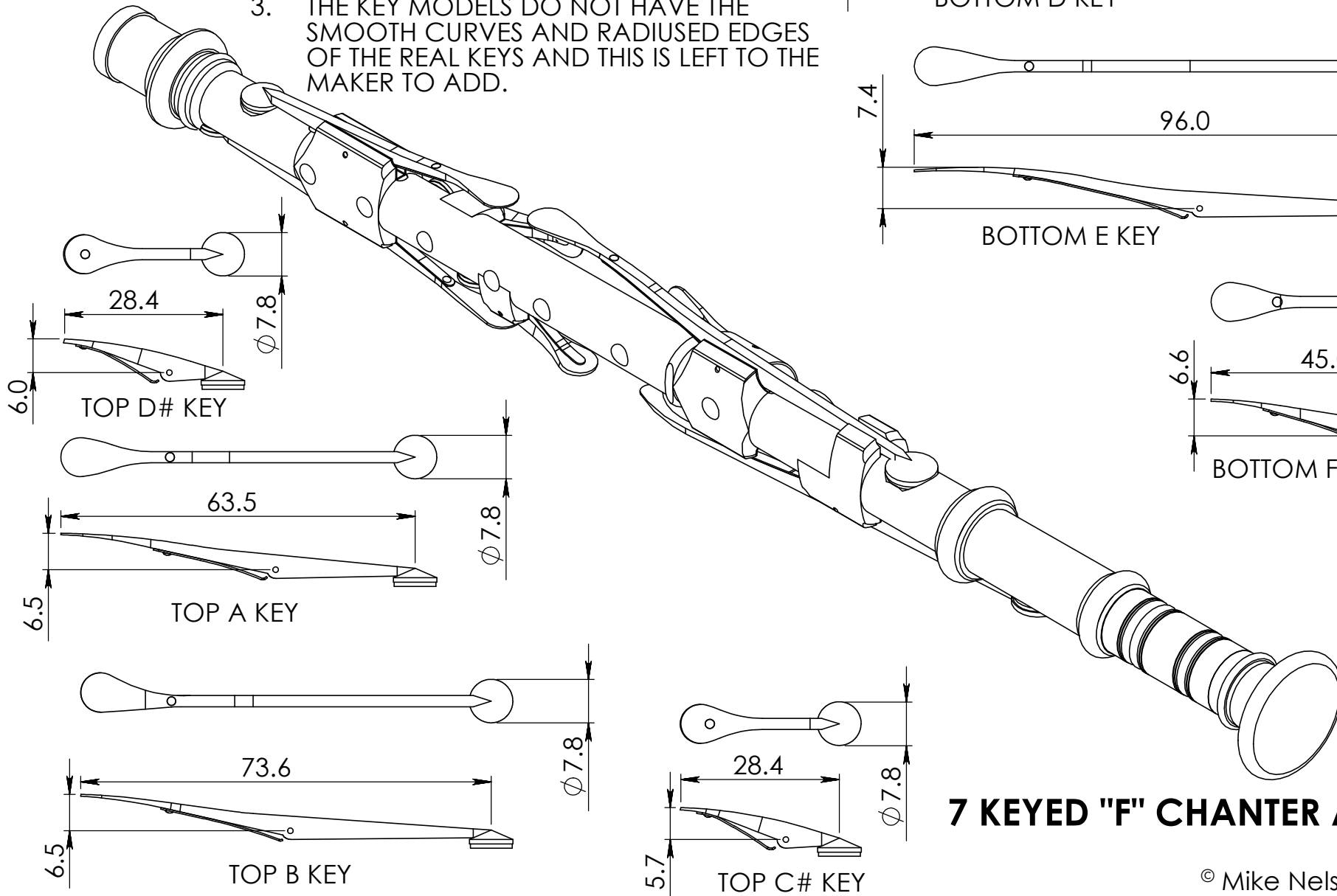

7 KEYED "F" CHANTER ASSEMBLY