

F9J "	89G7 F-DHC B	85H9	5DDFC J 98
6		& # \$ * # & \$ \$ -	

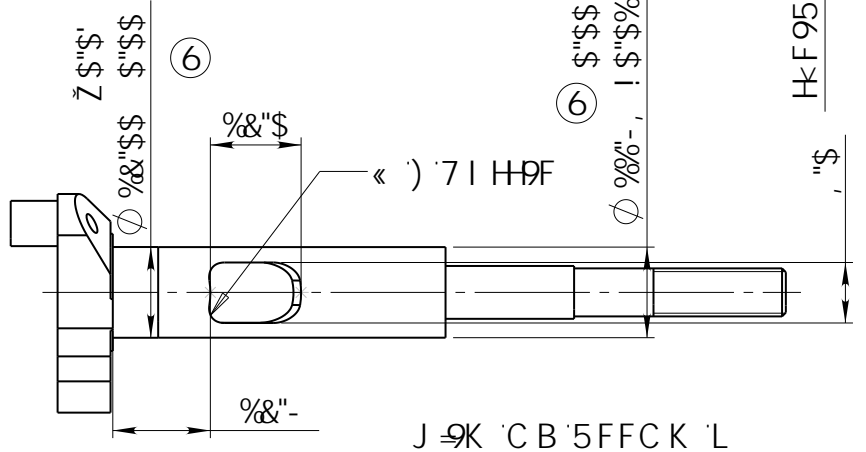
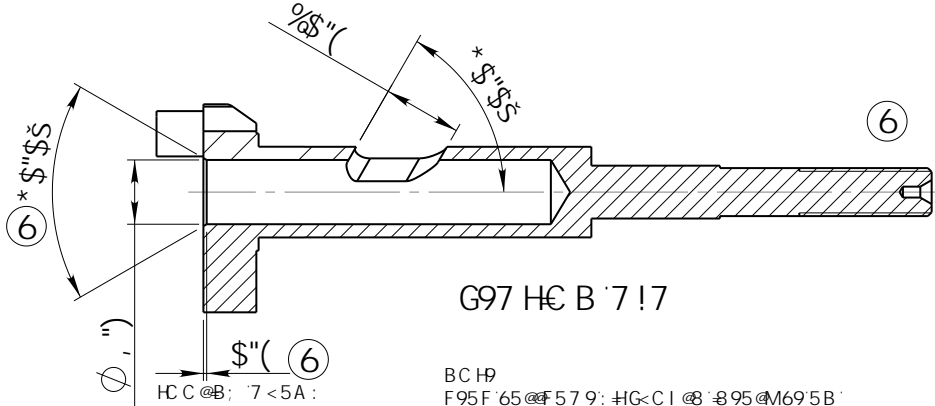
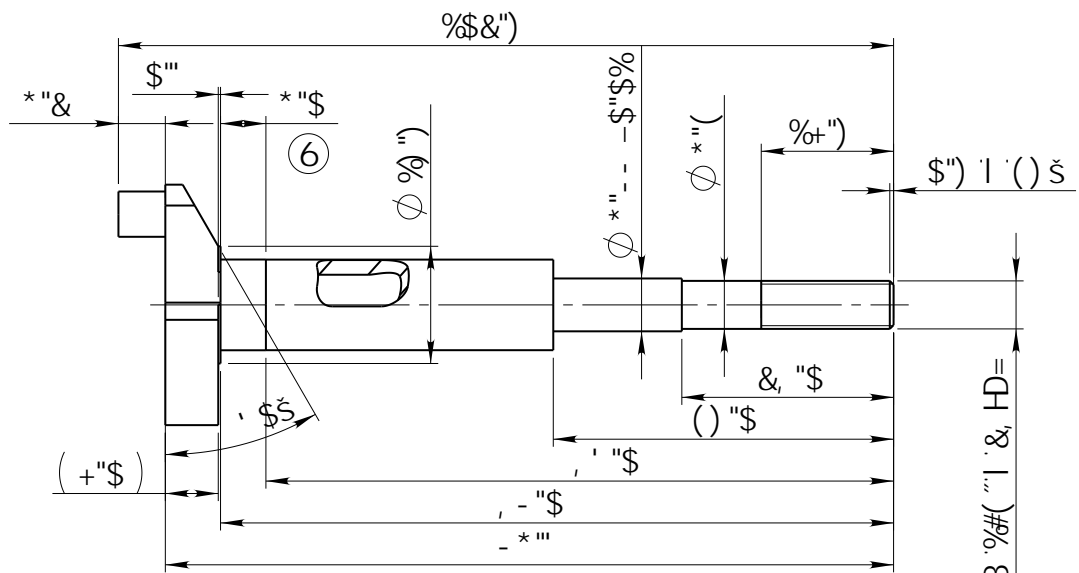
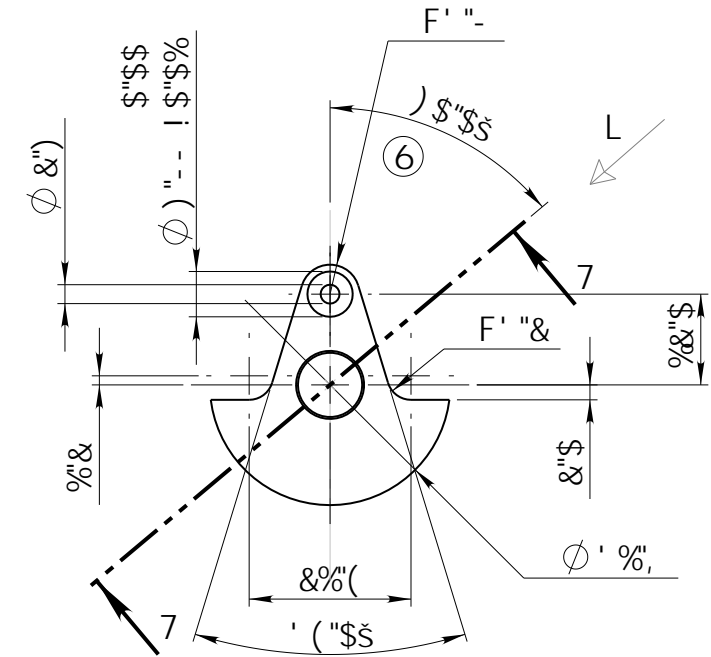

BCHP  
 F95F '65 @ F 57 9: #IG-C1 @8 '895 @M695B  
 BHPF: 9F9B7 9: HC: '56C I H '\$ '\$ \$8) fC "\$ \$ % ' ! > GH  
 56 @ HC '69DF9CG98 'CB 'K #K: MCI F: B; 9FG

⑦ A UWX ]bY '7 cbWXd h @X  
 \* : ]Y'Xj ]Yk ž'6Uf<']  
 7 Ua VfX [ Yž '7 6&' ; GL"  
 l b]hYX ?]b [ Xca  
 HY : Ž (( f \$ L % ) ( + , \$ ++ &  
 a [Y4 a UWX ]bYWc bWXd hg"Vc "i \_

5" Xja YbgjcbgUfy ]b'a a  
 i bYggcHYfk ]y' gUNX"  
 Bc 'XYWd' : ± '\$) a a  
 %XYWd' : ± '\$&a a  
 &XYWd' : ± '\$%a a  
 ' XYWd' : ± '\$\$) a a  
 Ub[ i 'Uf: ± '\$&  
 8C BCHG7 5 @

0: A0'E  
 A FB  
 T a a' a a E  
 9B '&(

0: A0'E  
 0 @ a 0'E  
 0: A0'E  
 T [ a ] a a a ^  
 g U Zh  
 0: A0'E  
 & # \$ \* # & \$ \$ -  
 % %  
 H FB9F '\* % @ H @ 7 F5B ? G < 5 : H  
 0: A0'E  
 6H \$ )  
 0: A0'E  
 U @ ^ a a ^ E  
 5 ( % c Z %

