

F9J "	89G7 F-DHC B	85H9	5DDFC J 98
6	HC @58898	& #*\$ #&\$-\$	A FB

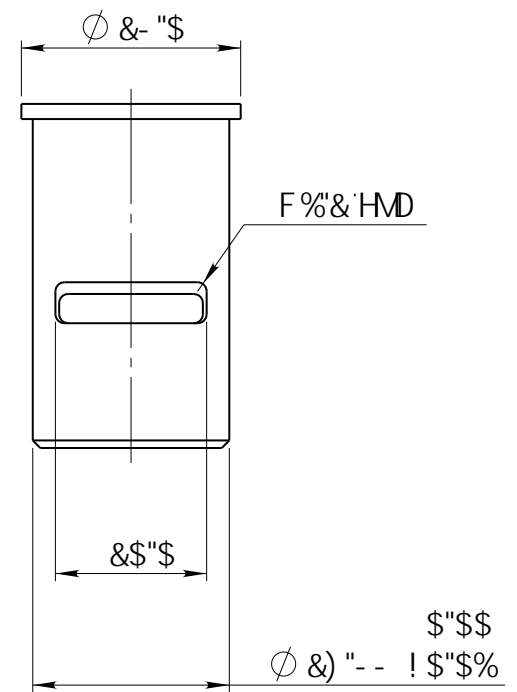
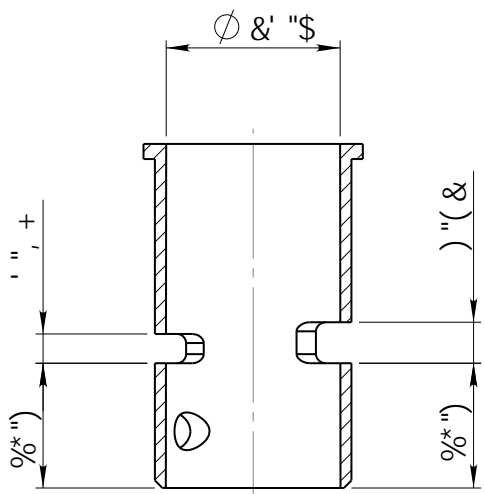
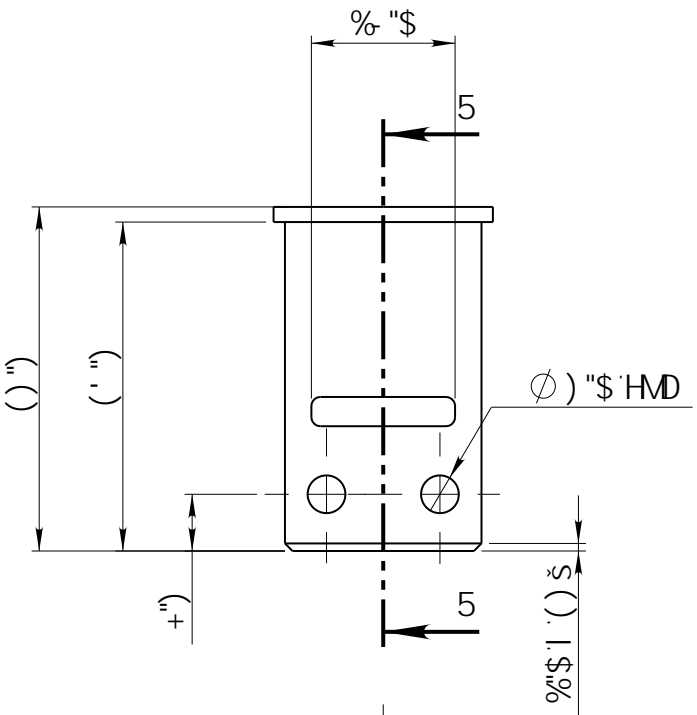

G97 HC B '5!5 BC H9'H5 D9F

⑥

⑦ A UWX]bY '7 cbWXd h@X
 * :]Y`Xj]Yk ž6Uf<]
 7 Ua VfX [Yž'7 6&' ; GL"
 l b]hYX ?]b[Xca
 HY` Ž((f\$E'%) (+, \$++&
 a]Y4 a UWX]bYVc bWXd hg"Vc "i _

5`X]a Ybg]cbgUfy]b'a a
 i b'YggchYfk]y' g'UNX"
 Bc 'XYWd' . ± \$') a a
 %XYWd' . ± \$'&a a
 &XYWd' . ± \$'a a
 ' XYWd' . ± \$'\$) a a
 Ub[i 'Uf. ± \$'&°
 8C B'CHG7 5@



' fx'5b['Y

0' A' E A FB

6F5GG7 N%&%

7 <FCA 9'BG89CB@M

T[a^Aa^ ^ WnjbXYf

H FB9F '*%@H@G7 M@B89F

6H \$* 5(%cZ%